

Stone Strong Anchors

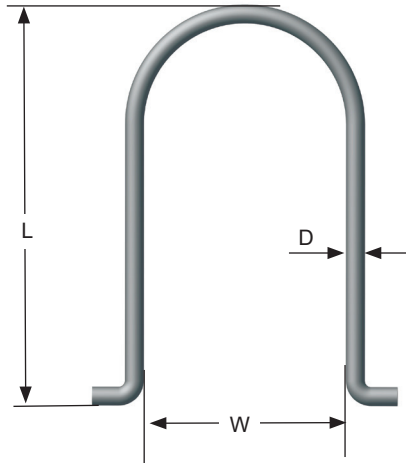

Conac Stone Strong Anchors

The CONAC Stone Strong anchors are engineered to handle all sizes of Strong Stone products. They are made of galvanized carbon steel. They are the only anchors approved by Strong Strong Company.



ITEM #	ANCHOR WIRE DIAMETER (D)	W	L	WEIGHT	SWL (LBS)
CSSA-10	14 mm (9/16")	7-1/2"	15"	2.45 LB	6500
CSSA-16	16 mm (5/8")	7-1/2"	16-1/2"	3.5 LB	8000
CSSA-10-18	18 mm (11/16")	7-1/2"	15"	3.90 LB	10000

Safe working loads based on approximate 4:1 Safety Factor in 2,200 psi normal weight concrete.

CSSA-10 used in 6-44 and 3-44 blocks.
 CSSA-10-18 used in the 24SF blocks.

The CONAC Stone Strong Anchor has been tested in actual Stone Strong elements and proven to exceed required load capacities. Test results are available upon request.

