

Flat Steel System

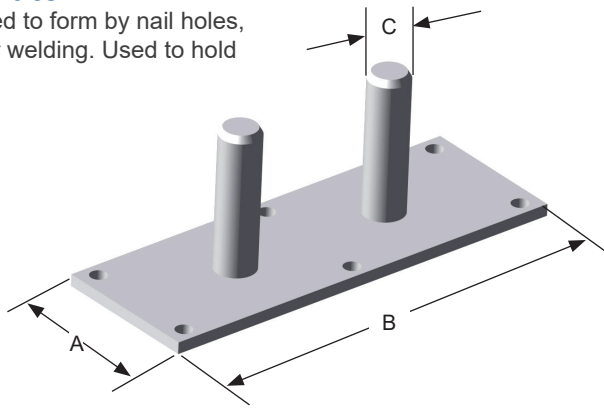

Holding Plate

May be attached to form by nail holes, screw holes, or welding. Used to hold recess former.



TON	ITEM CODE	A	B	C	SYSEM CODE
2T	FHP02	5/8"	2-3/4"	10mm	2.5T
4T	FHP04	1-1/4"	3-3/8"	10mm	5.0T
8T	FHP08	1-3/4"	4-7/8"	12mm	10.0T
22T	FHP22	2-1/2"	7"	16mm	22.0T

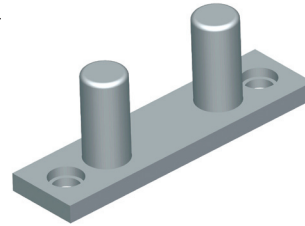

Wing Nut & Bolt Assembly

Used to attach recess former to form.

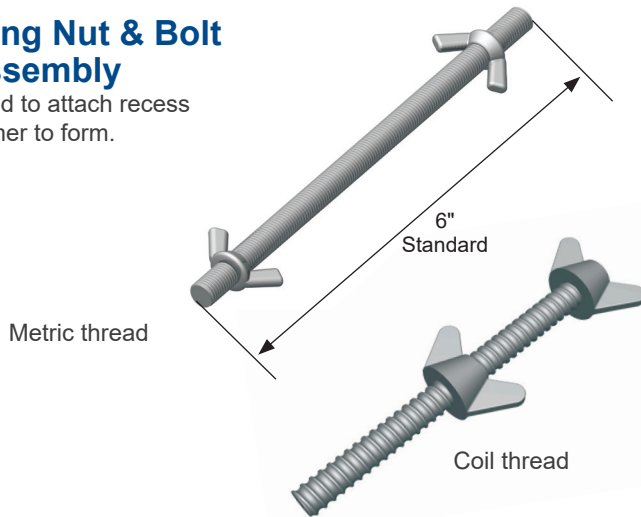

TON	ITEM CODE	STANDARD ROD LENGTH	THREAD DIAMETER & TYPE	SYSTEM CODE
2T	FWN02	6"	M8	2.5T
4T	FWN04	6"	M8	5.0T
8T	FWN08	6"	M12	10.0T
22T	FWNC 1/2"	5-1/2"	1/2" COIL	22.0T
	FWNC 1/2"	5-1/2"	1/2" COIL	5.0T
	FWNC 3/8"	6"	3/8" COIL	5.0T

Shear Bar

Used with flat steel erection anchor to increase shear capacity.

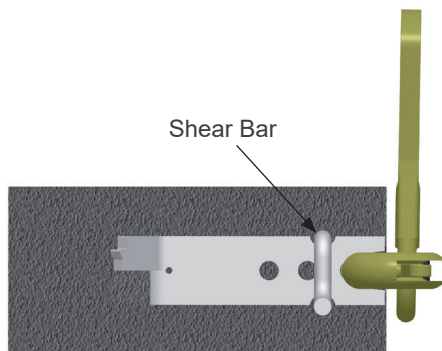

TON	ITEM CODE	SHEAR BAR DIAMETER	MIN. PANEL THICKNESS	HIGH (H)	LENGTH (L)	SYSTEM CODE
2T	FSB02	1/2"	4"	2-1/2"	13-7/8"	2.5T
4T	FSB04	1/2"	5-1/2"	3-5/16"	13-7/8"	5.0T
8T	FSB08	1/2"	7-1/2"	4-15/16"	13-7/8"	10.0T

