

# A-Anchor™

## Lifting System

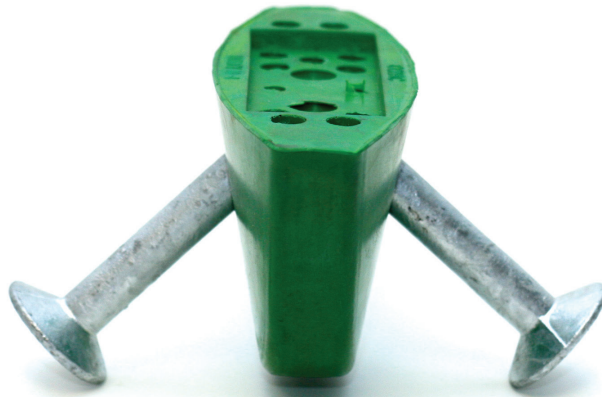

The CONAC A-Anchor Lifting System is versatile and economical, easy to work with in precast concrete plants as well as in the field. The system allows the use of a standard hook or clevis, eliminating the need for specialized lifting hardware.

# A-ANCHOR

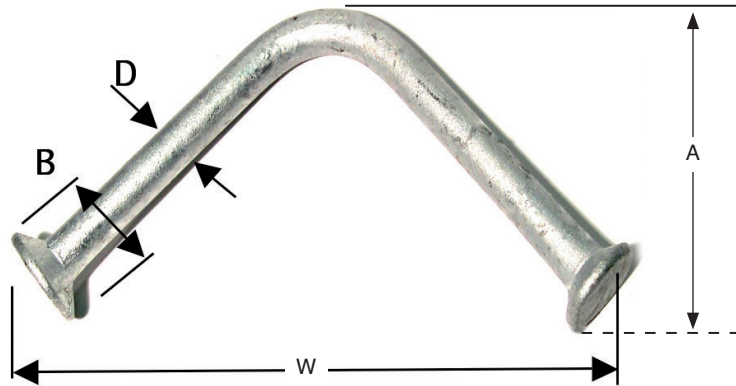

PRODUCT CODE	SLAB MIN. 90°	SWL TENSION	SWL AT 90° SHEAR	END DISTANCE
4CA12	4"	2,600	4,000	
4CA14	4"	3,500	5,400	9"
5CA14	5"	5,500	8,500	10"
5CA18	5"	6,000	9,300	10"
6CA14	6"	6,500	10,100	12 1/2"
6CA18	6"	7,500	11,600	12 1/2 "
8CA18	8"	13,000	20,000	15 1/2 "

PRODUCT CODE	ANCHOR DEPTH (A)	ANCHOR WIDTH (W)	BODY DIAMETER (D)	BASE DIAMETER (B)	PANEL DEPTH
4CA12	3-1/4"	5-1/8"	1/2"	1-3/16"	4"
4CA14	3-1/8"	6-5/16"	9/16"	1-3/16"	4"
5CA14	3-3/4"	8-1/4"	9/16"	1-3/16"	5"
5CA18	3-3/4"	8-11/16"	11/16"	2"	5"
6CA14	4-3/4"	10-9/16"	9/16"	1-3/16"	6"
6CA18	4-3/4"	9-1/16"	11/16"	2"	6"
8CA18	6-3/4"	12-1/4"	11/16"	2"	8"

Note: Safe working Load provides a factor of safety of approximately 4:1 based on a minimum concrete strength of 4,000 psi. For use as pulling iron load maybe increased by 33% with 3 to 1 Safety Factor.

## A-ANCHOR RUBBER RECESS FORMERS

The A Anchor Rubber Recess Formers are manufactured in 90° angles. The recess former properly sets the top of the anchor 3/4" below the surface of the concrete.

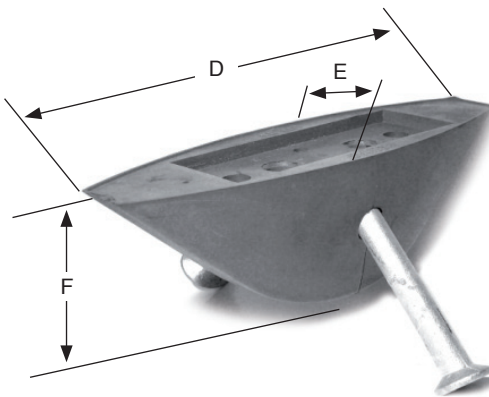

PRODUCT CODE	D	E	F	COLOR
CRRF9014	9.00"	3"	3.25"	Red
CRRF9018	9.00"	3"	3.25"	Black
CRRF9014-4	9.00"	3"	4"	Yellow
CRRF9018-4	9.00"	3"	4"	Green

## A-ANCHOR PLASTIC RECESS FORMERS

A-Anchor single use plastic recess formers attach to mesh or rebar cages. Patent # 8,024,896

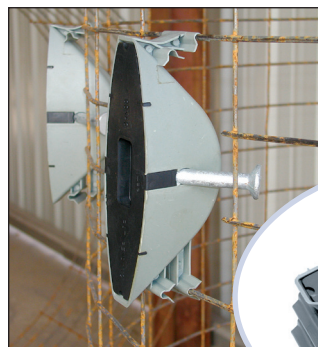

PRODUCT CODE	D	E	F	QTY/BOX
A-PRF-1	9.00"	3"	3.25"	130 PCS
A-PRF-1-18	9.00"	3"	3.25"	130 PCS
A-PRF-3-4	11.00"	4-1/8"	4"	60 PCS

# A-ANCHOR

CONAC  
Concrete Product Solutions

## A-ANCHOR MAGNETIC RECESS PLATE

The A Anchor Magnetic Recess Plate allows attachment of the Rubber Recess Former to any steel form, eliminating bolting or welding. Threaded holes in magnet (3/8"-16 NC) allow easy release of magnet from form.

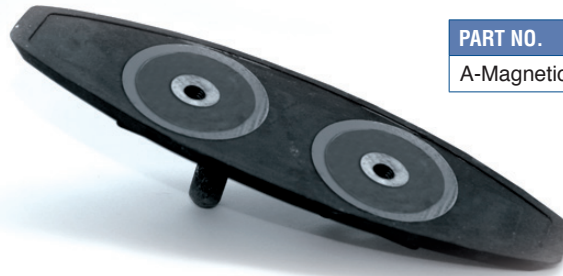

PART NO.

A-Magnetic Plate

## A-ANCHOR SETTING PLATE

The A-Anchor Setting Plate is used in various applications to install A-Anchors in a form.

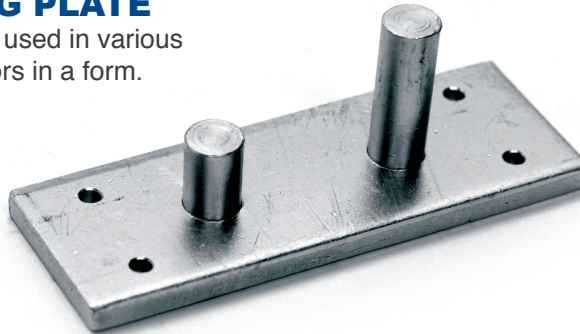

PART NO.

A-Setting Plate

## A- ANCHOR SETTING ROD

The Setting Rod is used to set the recess former in place by way of a predilled hole in the form.



PART NO.

A-Setting Rod

3/8"-16 NC thread, For use with rubber Recess Formers.