

Ferrules

Connections



FERRULES



Note: Ferrule inserts are for connections only and should not be used for lifting. All ferrule inserts should be set back 1/2" from face off concrete. Standard finish is electroplated. Also available plain (Self Colored).

FERRULE LOOP INSERTS

N/C closed end threaded ferrule is welded to a single round loop strut. Intended as a connection insert.

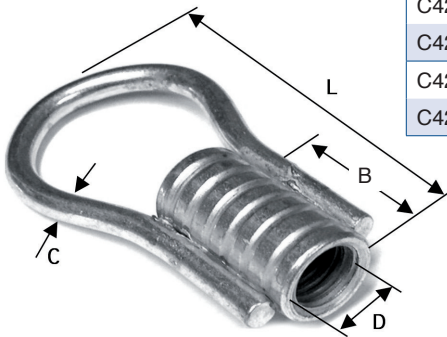

PART NO.	THREAD (D)	INSERT LENGTH (L)	THREAD DEPTH (B)	WIRE DIAMETER (C)	SWL (LBS)	SUGGESTED EDGE DISTANCE
C42F025	1/4"-20 NC	2-3/4"	3/4"	0.262"	650	5"
C42F038	3/8"-16 NC	2-3/4"	3/4"	0.262"	2000	5"
C42F050	1/2"-13NC	2-3/4"	1"	0.262"	2000	5"
C42F058	5/8"-11 NC	3-1/4"	1-1/8"	0.262"	2400	5"
C42F075	3/4"-10 NC	3-1/2"	1-1/8"	0.262"	2400	5"
C42F078	7/8"-9 NC	3-1/2"	1-1/8"	0.375"	5300	8"
C42F100	1"-8 NC	6"	1-1/8"	0.375"	5300	8"

Note: SWL provides a factor of safety of approximately 3:1 in 3,000 psi normal weight concrete. Stainless steel available in some sizes.

CONNECTION SYSTEMS

FERRULE ONLY

Plain ferrule can be furnished for fabricating special inserts at the job site.

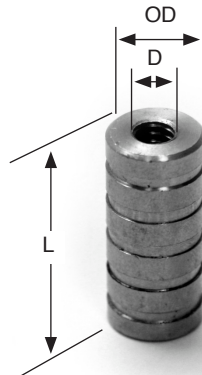

PART NO.	THREAD (D)	LENGTH (L)	OUTSIDE DIA. (OD)
C43F025	1/4" - 20 NC	1-1/4"	9/16"
C43F038	3/8" - 16 NC	1-1/4"	9/16"
C43F050	1/2" - 13 NC	1-3/8"	11/16"
C43F058	5/8" - 11 NC	1-5/8"	7/8"
C43F075	3/4" - 10 NC	1-5/8"	1"
C43F078	7/8" - 9 NC	1-5/8"	1-1/4"
C43F100	1" - 8 NC	1-5/8"	1-3/8"

Note: SWL provides a factor of safety of approximately 3:1 in 3,000 psi normal weight concrete. Stainless steel available in some sizes.

THIN SLAB FERRULE INSERTS

Very versatile insert intended for use as an anchorage insert in relatively thin slab concrete. N/C closed end ferrule insert is welded to parallel struts. Intended as a connection insert.

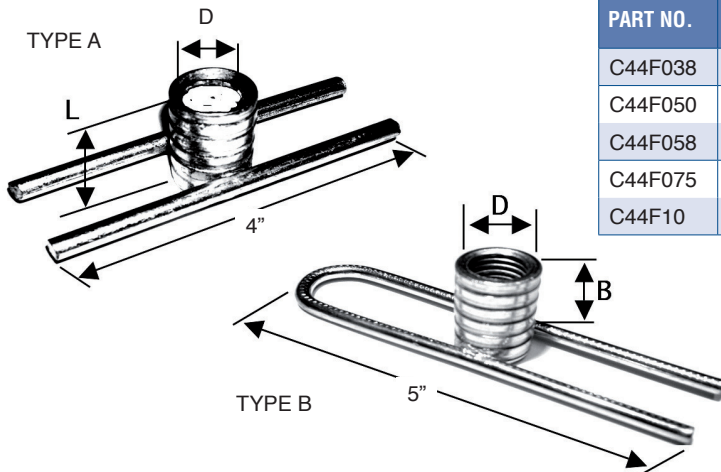

PART NO.	THREAD (D)	INSERT LENGTH (L)	THREAD DEPTH (B)	SWL (LBS)	SUGGESTED EDGE DISTANCE
C44F038	3/8"-16 NC	1-1/4"	3/4"	450	2-1/2"
C44F050	1/2"-13 NC	1-3/8"	3/4"	900	2-3/4"
C44F058	5/8"-11 NC	1-5/8"	1"	1000	3"
C44F075	3/4"-10 NC	1-5/8"	1-1/8"	1600	3"
C44F10	1"-8 NC	1-5/8"	1-1/8"	1600	3"

Note: SWL provides a factor of safety of approximately 3:1 in 3,000 psi normal weight concrete.

FERRULES

Note: Ferrule inserts are for connections only and should not be used for lifting. All ferrule inserts should be set back 1/2" from face off concrete. Standard finish is electroplated. Also available plain (Self Colored).

THIN SLAB 4 LEG FERRULE INSERTS

Very versatile insert intended for use as an anchorage insert in relatively thin slab concrete. N/C closed end ferrule insert is welded to 4 "L" shaped legs. Intended as a connection insert.

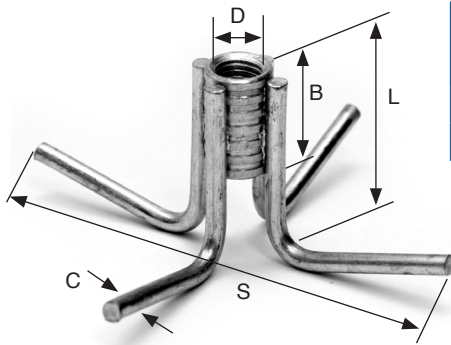

PART NO.	THREAD (D)	INSERT LENGTH (L)	THREAD DEPTH (B)	WIRE DIAMETER (C)	SPREAD (S)	SWL (LBS)	SUGGESTED EDGE DISTANCE
C52F0753	3/4"-10 NC	3"	1-1/8"	0.306"	7-1/6"	2650	7"
C52F104	1"-8 NC	4"	1-1/8"	0.375"	9-3/8"	4000	9"

Note: SWL provides a factor of safety of approximately 3:1 in 3,000 psi normal weight concrete.

EXPANDED FERRULE INSERTS W/2 OR 4 STRUTS

A Ferrule is welded to two or four wire side struts. At the opposite end of the struts from the thread ferrule is an expanded wire embedment coil. These inserts offer a wide degree of casting versatility and high strength for a variety of conditions.

PART NO.	THREAD (D)	INSERT LENGTH (L)	THREAD DEPTH (B)	WIRE DIAMETER (C)	SPREAD LENGTH (R)	SPREAD (S)	SWL (LBS)	SUGGESTED EDGE DISTANCE
C57F-3/4	3/4"-10 NC	4-5/8"	1-1/8"	0.440"	1-1/2"	2-1/4"	4250	6"
C57F-1	1"-8 NC	5-5/8"	1-1/8"	0.440"	2-1/4"	2-3/4"	6250	7"

Note: SWL provides a factor of safety of approximately 3:1 in 3,000 psi normal weight concrete.

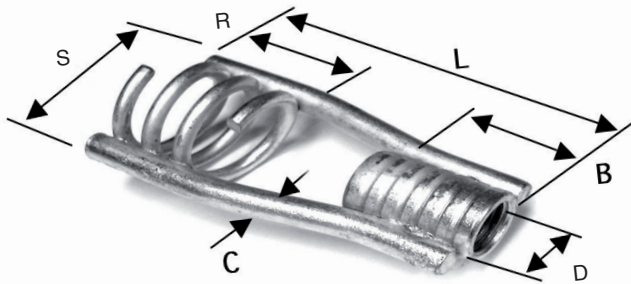

FLARED THIN SLAB FERRULE INSERTS (WING NUT STYLE)

N/C closed end threaded ferrule is welded to two "L" profile closed loop wire struts. Intended as a connection insert in thin slab concrete sections.

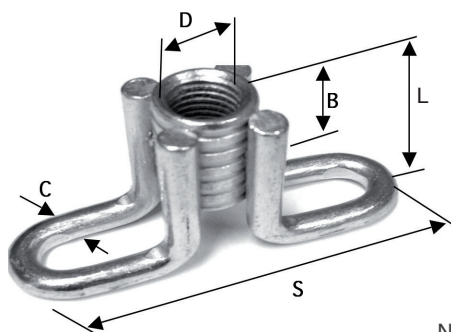

PART NO.	THREAD (D)	INSERT LENGTH (L)	THREAD DEPTH (B)	WIRE DIAMETER (C)	SPREAD (S)	SWL (LBS)	SUGGESTED EDGE DISTANCE
C62F05175	1/2"-13 NC	1-3/4"	1"	0.306"	4-3/4"	1200	5"
C62F05827	5/8"-11 NC	2-7/16"	1-1/8"	0.375"	4-3/4"	2500	5"
C62F07527	3/4"-10 NC	2-7/16"	1-1/8"	0.375"	4-7/8"	2650	5"
C62F07535	3/4"-10 NC	3-5/8"	1-1/8"	0.375"	4-7/8"	4500	7"
C62F10278	1"-8 NC	2-7/8"	1-1/8"	0.375"	5-1/8"	2650	5"
C62F10458	1"-8 NC	4-5/8"	1-1/8"	0.375"	5-1/8"	6300	8"

Note: SWL provides a factor of safety of approximately 3:1 in 3,000 psi normal weight concrete.

FERRULES



Note: Ferrule inserts are for connections only and should not be used for lifting. All ferrule inserts should be set back 1/2" from face off concrete. Standard finish is electroplated. Also available plain (Self Colored).

STRAIGHT FERRULE LOOP INSERTS

N/C closed end threaded ferrule is welded to a closed loop wire strut.

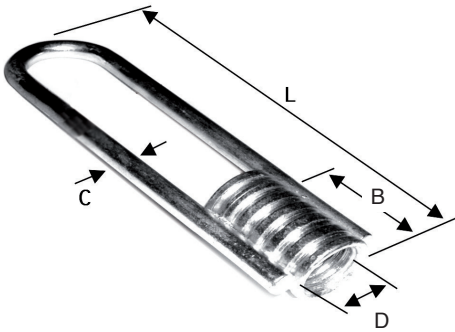

PART NO.	THREAD (D)	INSERT LENGTH (L)	THREAD DEPTH (B)	WIRE DIAMETER (C)	SWL (LBS)	SUGGESTED EDGE DISTANCE
C64F054	1/2"-13 NC	4-1/8"	1"	0.306"	3000	5"
C64F056	1/2"-13 NC	6-1/8"	1"	0.306"	5000	7"
C64F0584	5/8"-11 NC	4-1/8"	1-1/8"	0.375"	3000	5"
C64F0586	5/8"-11 NC	6-1/8"	1-1/8"	0.375"	5000	7"
C64F0754	3/4"-10 NC	4-1/8"	1-1/8"	0.375"	3000	5"
C64F0756	3/4"-10 NC	6-1/8"	1-1/8"	0.375"	5000	8"
C64F0786	7/8"-9 NC	6-1/8"	1-1/8"	0.375"	5000	8"
C64F106	1"-8 NC	6-1/8"	1-1/8"	0.375"	5000	8"
C64F108	1"-8 NC	8-1/8"	1-1/8"	0.375"	5000	8"

Note: SWL provides a factor of safety of approximately 3:1 in 3,000 psi normal weight concrete.

CONNECTION SYSTEMS

SEISMIC INSERTS

PART NO.	THREAD (D)	NOMINAL DEPTH (L)	THREAD DEPTH (B)	WIRE DIAMETER (C)	SWL (LBS)	BAR	SUGGESTED EDGE DISTANCE
SEISMIC 4-6"	1"-8 NC	6"	1-1/8"	0.375"	5670	4 Bars	6" or 9"
SEISMIC 4-8"	1"-8 NC	8"	1-1/8"	0.375"	5670	4 Bars	6" or 9"

Note: SWL provides a factor of safety of approximately 3:1 in 3,000 psi normal weight concrete.

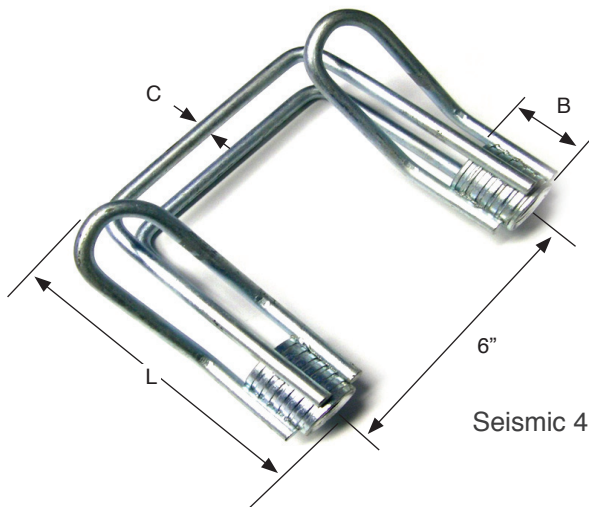

THREADED ZINC INSERTS



THREADED ZINC INSERT

Conac Threaded Zinc Insert is zinc alloy die cast. A high strength corrosive resistant precast insert. Should not be used for lifting.



PART NO.	THREAD SIZE	LENGTH	CAPACITY IN 3,500 PSI CONCRETE (LBS)	WT / 10
TSI 25x150	1/4"	1 1/12"	970	7
TSI 38x138	3/8"	1 3/8"	1,020	8
TSI 38x138ob*	3/8"	1 3/8"	1,020	8
TSI 50x150	1/2"	1 1/2"	1,750	18
TSI 50x150ob*	1/2"	1 1/2"	1,750	18
TSI 50x278	1/2"	2 7/8"	3,550	34
TSI 58x169	5/8"	1 11/16"	2,105	24
TSI 58x278	5/8"	2 7/8"	4,150	44
TSI 75x169	3/4"	1 11/16"	2,205	34
TSI 75x3	3/4"	3"	4,350	52

* ob: Open bottom

THREADED PLASTIC PLUGS

Can be used with any NC threaded insert. Can be nailed to wood forms



PART NO.	THREAD SIZE	COLOR	QUANTITY PER BOX
TP4014N	1/4" NC	brown	200
TP4015N	3/8" NC	black	200
TP4016N	1/2" NC	blue	100
TP4017N	5/8" NC	yellow	100
TP4018N	3/4" NC	green	100
TP4019N	7/8" NC	red	100
TP4010N	1" NC	blue	100